



Advanced Strength of Materials

Prof. Dr. Guilherme Ferreira Gomes

Chapter 2 – Stress Analysis

Question 1. For the following stress tensors compute the Eigenvectors and the principal stresses. To solve the cubic equations, utilize Matlab/Scilab routines. In the following table the stresses are given in MPa.

	σ_x	σ_y	σ_z	τ_{xy}	τ_{xz}	τ_{zy}
1	100	50	30	-67	-30	20
2	130	30	-27	-30	20	-40
3	-40	100	48	100	80	76
4	-180	-40	100	200	28	47
5	-300	-20	100	-38	20	-60
6	-100	-200	-150	60	76	-40

Question 2. For a circular beam, the usual engineering equations for the stress due to bending are:

$$\sigma_y = \sigma_z = 0 \quad \tau_{xz} = \tau_{yz} = 0$$

$$\sigma_x = \frac{My}{I} \quad \tau_{xy} = \frac{V(R^2 - y^2)}{3I}, \quad I = \frac{\pi R^4}{4}$$

Do these equations satisfy the equilibrium equations?

Question 3. For what body forces will the following stress field describe a state of equilibrium?

$$\begin{aligned} \sigma_x &= -2x^2 + 3y^2 - 5z & \tau_{xy} &= z + 4xy - 7 \\ \sigma_y &= -2y^2 & \tau_{xz} &= -3x + y + 1 \\ \sigma_z &= 3x + y + 3z - 5 & \tau_{yz} &= 0 \end{aligned}$$

Question 4. What are the normal and shearing stresses on the spiral weld of the aluminum shaft of diameter d subjected to an axial load P and a torque T (figure).

Given: $P = 120 \text{ kN}$, $T = 1.5 \text{ kN.m}$, $d = 40 \text{ mm}$ and $\phi = 50^\circ$.

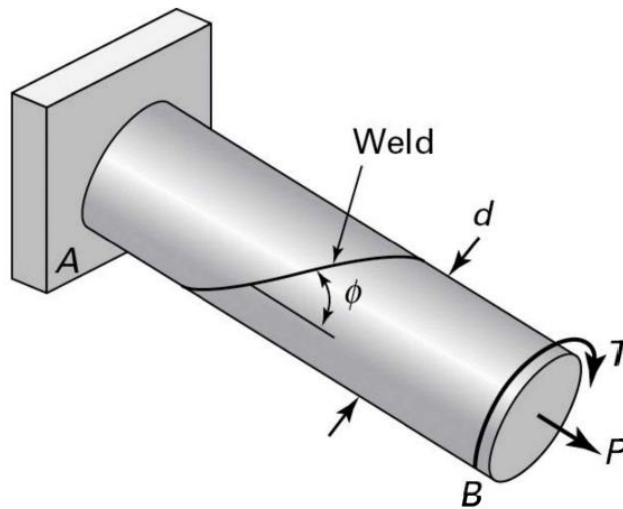

Question 5. Consider a point in a loaded instrument panel subjected to the stresses represented in the figure. Determine, the principal stresses and their orientation with respect to the original system. In addition, draw the Mohr's circle.

