



Advanced Strength of Materials

Prof. Dr. Guilherme Ferreira Gomes

Chapter 10 – Buckling and Elastic Stability

Question 1. A hydraulic cylinder is capable of exerting a force of 5200 N to move a heavy casting along a conveyor. The design of the pusher causes the load to be applied eccentrically to the piston rod as shown in Figure. Is the piston rod safe under this loading if it is made from SAE 501 OQT 1000 stainless steel?

Given: $\sigma_U = 1210$ MPa, $\sigma_Y = 931$ MPa and $E = 200$ GPa.

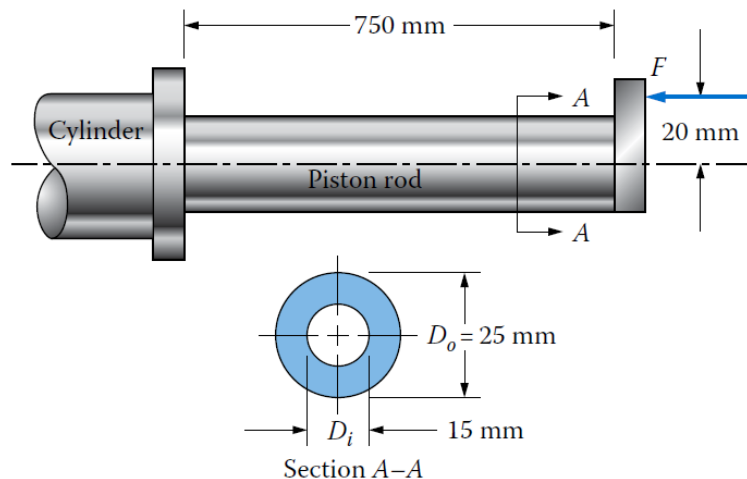

Question 2. A simply supported rectangular plate is subjected to a uniform axial compression N . The plate is constructed of high-strength, ASTM-A243 steel with $b = 200$ mm, $a = 2b$, $t = 4$ mm, $\nu = 0.29$, and $E = 200$ GPa. Calculate the critical load N_{cr} and buckling stress σ_{cr} .

